

The world's highest performing microprocessor optimized for multitasking and real-time processing  
**Cell Broadband Engine**

**Cell宽带引擎**

Cell has a heterogeneous multi-core architecture of nine core processors optimized for "multitasking and real-time processing". It is the key device in the next generation broadband era to manage rich digital media and video stream distributed on network.

- Integrating 8 SPEs for media processing and one PPE for general-purpose processing
- PPE is a 64-bit processor compliant with Power PC Architecture
- Each SPE has SIMD processing unit, 128 x 128-bit register files and 256KB Local Storage
- XDR\* of an external main memory is connected via memory controller of XIO\* integrated inside Cell
- The other external devices are connected via I/O interfaces of FlexIO\*

Cell是一种采用非对称多内核结构设计,发挥合计共使用9个处理器内核的「多任务/实时处理」的性能,在映像等各种大容量数据流通的下一代宽带时代中的重要器件。

- 搭载8个媒体运算内核SPE和1个通用内核PPE
- PPE是一种基于Power PC结构的64位处理器
- 各SPE包括SIMD型运算处理单元、128个128位寄存文件以及256KB的本地存储器
- 外置的主要存储器XDR\*通过XIO\*进行连接
- 其他外部芯片通过IO界面(FlexIO\*)进行连接

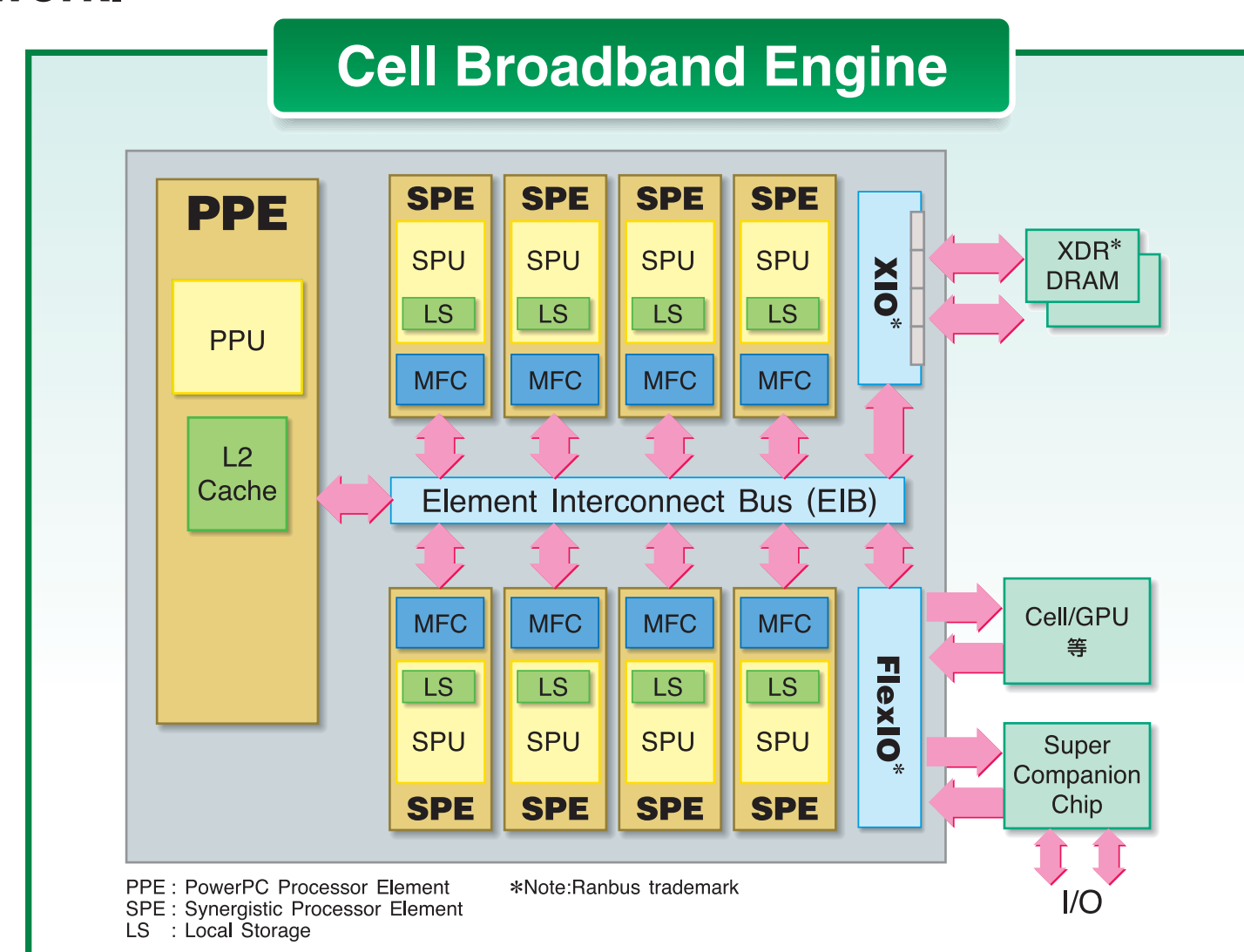

**TOSHIBA HDN**  
 东芝HDN

HDN: High Definition Network

**Device technology that powerfully supports HDN.**  
 东芝的元器件技术全力支持HDN。

**Role of Cell**  
 Cell处理器的功能

HDN elemental technology enabling asymmetric multi-core architecture for world's fastest multi-task/real-time processing  
 这项HDN基本技术实现了旨在世界最快多任务/实时处理的不对称多核心架构。