

多媒体加速器专为流动通讯及携带型终端机之应用

S1



Enabling multimedia functions for advanced mobile terminals in a compact size and running at low power

- **MeP** and DSP for realizing diverse multimedia functions
- Control optimization of **MeP** and DSP for realizing long hours of audio playback with low power consumption
- Firmware is loaded to the built-in DRAM for flexible responses to API advancements
- Large-capacity built-in DRAM is used for enabling a compact, low-power consumption
- Dedicated engines for JPEG and ZOOM for enabling 2-megapixel still images to be compressed in as little as 50 milliseconds

System Block Diagram

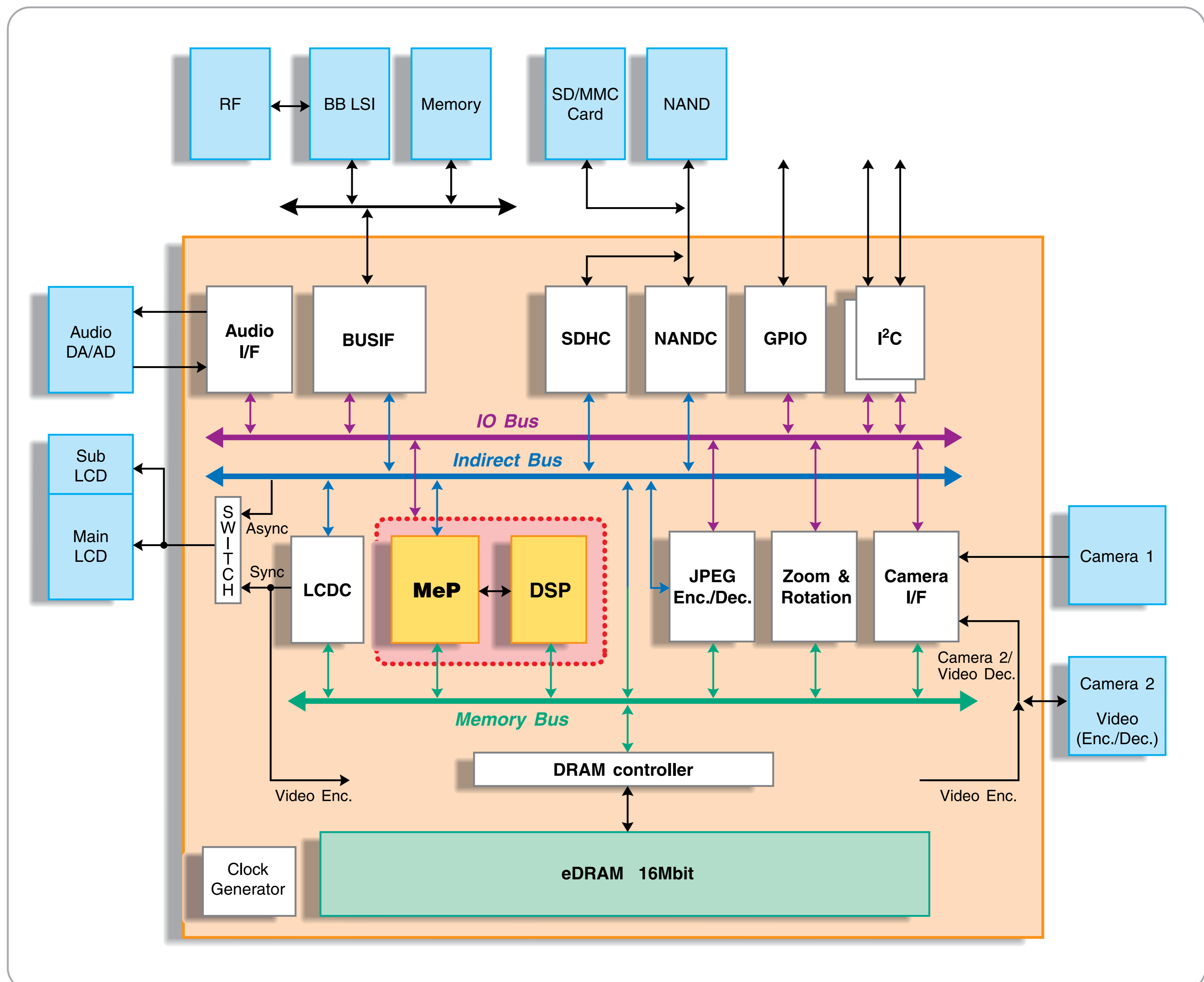

※ The system and product names contained in this document are trademarks or registered trademarks of their respective companies.